

Product:	MultiTrode Probe
Notes:	Correct probe installation and troubleshooting

Probe Installation & Troubleshooting

1 Correct Probe Installation

1.1 Important Notes

- Hang probe in turbulent area of wet well
- Do not install the probe in a stagnant area or corner where grease and debris may collect. Stilling wells are not suggested.
- Ensure a minimum of 300 mm (12 inches) clearance from any surface
- Ensure bottom of probe is 12.5 mm (½ inch) above minimum pumping level
- Do not use the bottom sensor as earth or ground
- The Probe cable must be buried (outside the well) in a separate metal conduit and shielded for correct operation of the level-sensing device
- Most pits are adequately earthed or grounded and do not require any reference rods, however PVC or Fibre Glass Tanks without pumps or metallic grounded pipe require reference rods

2 Probe Location

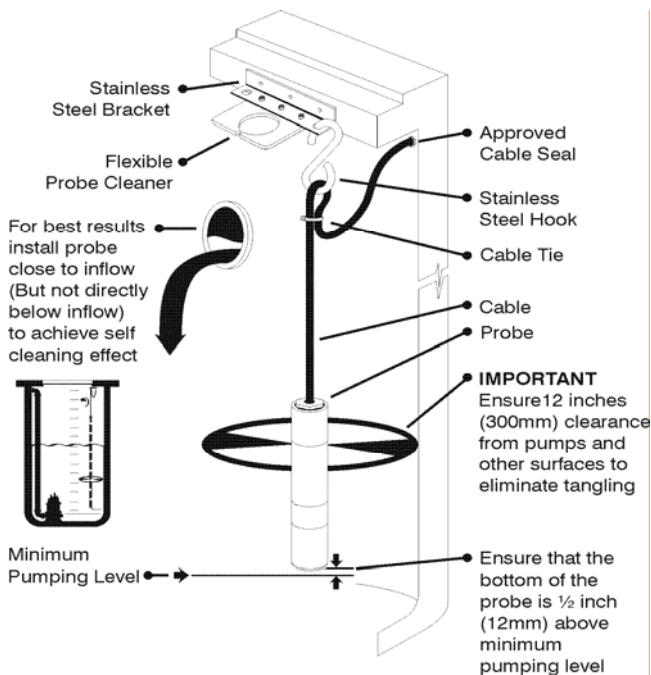

Figure 1 - Locating the probe in the vessel

The MultiTrode probe is designed to be supported on its control cable (see Fig.1) from the Suspension/Cleaning bracket supplied with the probe. It is desirable for the probe to be located near the inflow in a reasonably turbulent area of the wet well.

The inflow should not be allowed to run directly on to the probe, but the surface agitation of the inflow area is beneficial in keeping the probe clean. Before deciding on the probe location, the wet well should be pumped down as far as possible and the probe suspended from its approximate position to ensure that adequate clearance exists from objects in the pit. A minimum of 300 mm (12 inches) clearance should be maintained from any conductive surfaces.

Product:	MultiTrode Probe
Notes:	Correct probe installation and troubleshooting

3 Mounting

Fix the Suspension/Cleaning Bracket (Fig.1) on to the inside of the wet well, ensuring the clearance form covers and the ladder access. To mount the probe, first thread the cable through the stainless steel hook provided. Place the hook onto the mounting bracket or eyeball and adjust the cable length until the bottom of the probe is 12.5 mm (½") above the minimum liquid level.

Fasten the cable to the hook using cable ties. Draw the loose end through the conduit to the control panel.

4 Cleaning

Provide sufficient slack in the cable to allow the probe to be drawn through the cleaning bracket (Fig.1), or taken out of the well for cleaning. MultiTrode systems are designed so that the need for probe cleaning is greatly reduced or eliminated. This is achieved by correctly, positioning the probe and selecting sensitivity on the level controller.

5 Accessories

5.1 MTAK 2 Extended Mounting Bracket

The MTAK-2 (Fig.2) is an optional extra. It is made from 2.5mm (1/8") 3/16 stainless steel and can be used with all multi-sensored probes to give a greater, free-swinging area. It has an in-built squeegee blade style probe cleaner and includes stainless steel hook and cable ties.

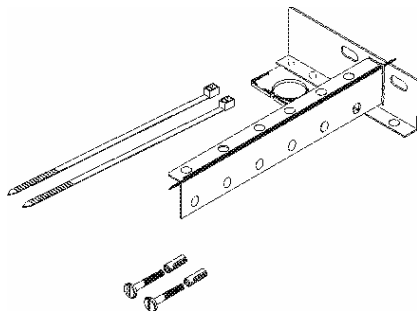

Figure 2 - MTAK 2 Extended Mounting Bracket Kit

6 How the MultiTrode Probe Works

As the level rises and contacts the probes sensor/s a circuit is completed.

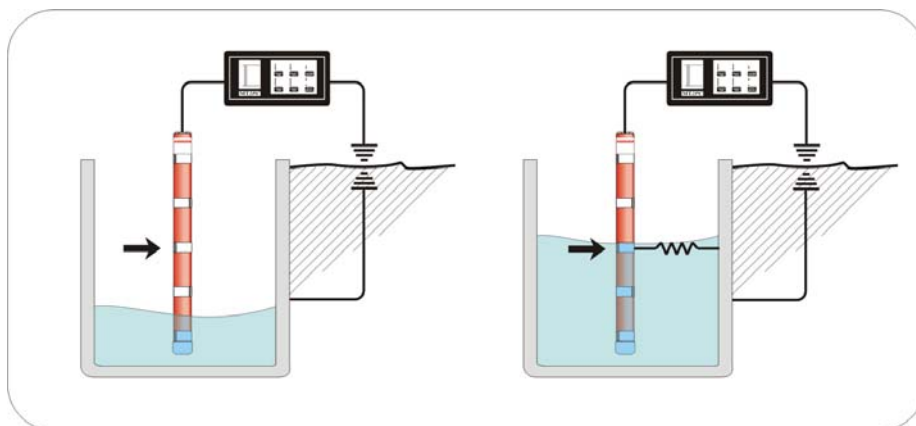

Figure 3 - How the probe works

Product:	MultiTrobe Probe
Notes:	Correct probe installation and troubleshooting

7 Probe Theory

The probe is manufactured from uPVX moulded Housing incorporating 2 sensor points of Avesta 254 SMO high-grade stainless alloy.

The probe has no moving parts and no electronic components inside; the probe utilizes the conductive state of the liquid to complete a circuit.

If tank is PVC or fibreglass and has no metal grounded objects such as pumps, then the system will need a ground reference rod. MultiTrobe suggests a 6mm stainless steel rod suspended in liquid, then grounded.

8 Trouble Shooting

Controller fails to activate (when expected)	<ul style="list-style-type: none"> Remove probe connection from controller Short circuit the probe inputs on the controller to ground, start with p10 working your way down to p1
Does the controller activate?	<ul style="list-style-type: none"> No, Setup problem or actual faults on controller - go to trouble shooting guide or the product manual Yes, This means controller functional - while the probe (or probe segment) is immersed measure the resistance to ground of that sensor with a high Ω resistance meter. Is it open circuited? <ul style="list-style-type: none"> Yes - end of issue – wires faulty – check for damages cables No – Check grounding on earth rod in pit, and grounding on Controller, check for earth continuity across installation <p><i>Note: External contamination such as excess oil can insulate probe in areas such as wash down plants and workshops for diesel motors.</i></p>
Pumps activate prematurely	<ul style="list-style-type: none"> Check sensitivity setting on controller. Set to next lowest setting. <p><i>Note: This is caused by external contaminates of sticky composition, and also very conductive – can cause premature activation in some industrial applications.</i></p>
Excessive fat build-up on probes	<ul style="list-style-type: none"> Move probe to a more turbulent area of pit, preferably close to inflow
Probe works erratically	<ul style="list-style-type: none"> Check any junctions in probe cable, especially where moisture can penetrate. <p><i>Note: Running the probe cable in the same conduit as pump power cables can cause inductance into probe cable and give false readings.</i></p>
High alarm activates after some delay when sensor is immersed	<ul style="list-style-type: none"> Check build-up on sensor – clean <p><i>Note: This may be caused by some areas containing heavy sludge such as finals of treatment plants, the sludge can, over extended time, dry out over sensor. A delay of 20 to 60 seconds can be experienced due to moisture slowly penetrating build-up. Increasing sensitivity will also remedy the problem.</i></p>